

Truck Champ

INSTALLATION INSTRUCTIONS STEELCRAFT 3" SIDEBARS

**08-09 HONDA CRV
PART # PLW80020**

PARTS LIST:

1	Driver Side Bar	20	8-1.25mm x 30mm Hex Head Bolts
1	Passenger Side Bar	20	8mm Lock Washers
1	Rear Driver Side Mounting Bracket (A)	20	8mm x 22mm x 3mm Flat Washers
1	Front Driver Side Mounting Bracket (B)		
1	Front Passenger Side Mounting Bracket (C)		
1	Rear Passenger Side Mounting Bracket (D)		

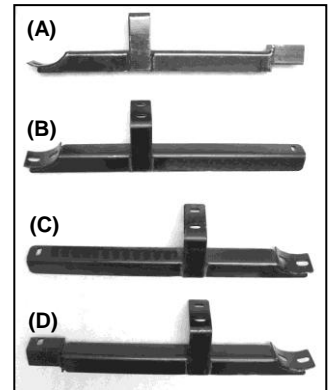

PROCEDURE:

- 1. REMOVE CONTENTS FROM BOX. VERIFY ALL PARTS ARE PRESENT. READ INSTRUCTIONS CAREFULLY BEFORE STARTING INSTALLATION.**
- Determine driver and passenger Mounting Brackets.
- Hang the inner side of the driver front Mounting Bracket into position by partially threading (1) 8mm x 30mm Hex Head Bolt, (1) 8mm Lock Washer, and (1) 8mm Flat Washer into factory threaded hole on the frame (**Figure 1**). **NOTE:** There are two threaded holes by the front mounting location on the frame, use the one towards the rear of vehicle.
- Attach the opposite side of the driver front Mounting Bracket to the threaded holes on the floor panel of the vehicle by partially threading (2) 8mm x 30mm Hex Head Bolts, (2) 8mm Lock Washers, and (2) 8mm Flat Washers (**Figure 1**).
- Locate and cut out the openings in the driver and passenger side trimming templates with a pair of scissors (Page 3 & 4)
- Fit the driver's side template onto its respective side plastic rock shields. Position them using two each of the 8mm bolts that will later be used to mount the side bar brackets. Transfer the openings in the templates onto the plastic cover using a magic marker.
- Now remove the rock shield from the undercarriage of the car. The three front screws can be removed with a 10MM socket. The plastic retainer plugs can be removed with a flat blade screwdriver.
- Using a sharp knife or pair of shears, cut out the shields as marked using the templates (**Figure 2**).
- Insert the inner side of driver rear Mounting Bracket through previously cut out hole on the plastic cover. Hang Mounting Bracket by partially threading (1) 8mm x 30mm Hex Head Bolt, (1) 8mm Lock Washer, and (1) 8mm Flat Washer into factory threaded hole on the frame (**Figure 3**). **NOTE:** There are two threaded holes on the frame, use the one towards the rear of vehicle.
- Attach the opposite side on the driver rear Mounting Bracket by partially threading (2) 8mm x 30mm Hex Head Bolts, (2) 8mm Lock Washers, and (2) 8mm Flat Washers into factory threaded holes on the floor panel.
- Position Driver Side Bar onto Mounting Brackets. Attach Side Bar to Mounting Brackets using the included (4) 8mm x 30mm Hex Head Bolts, (4) 8mm Lock Washers, and (4) 8mm Flat Washers (**Figure 1**). Do not tighten at this time.
- Level and adjust Side Bar; then tighten all hardware at this time.
- Re-install the rest of fastener on the rock shield.
- Repeat steps 2-13 for passenger Side Bar.
- Do periodic inspections to the installation to make sure that all hardware is secure and tight.

Front Driver Side Mounting Bracket Shown

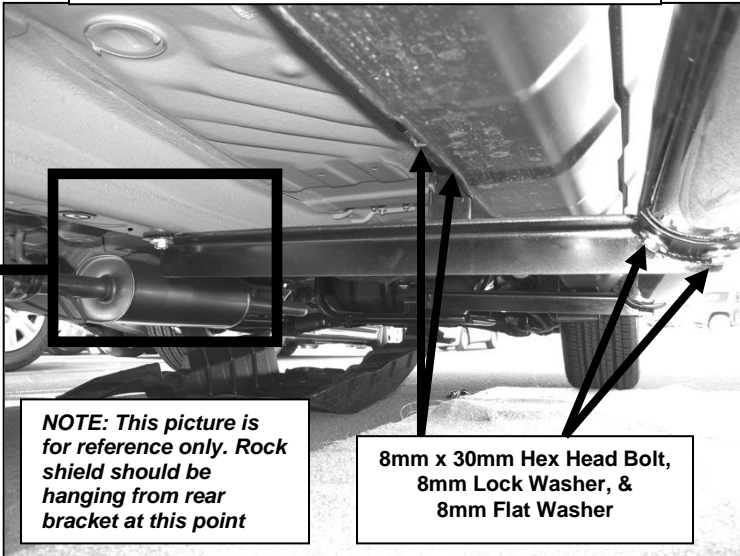
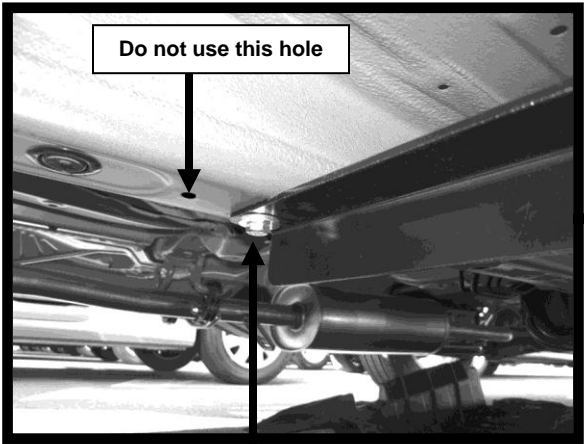

Figure 1



8mm x 30mm Hex Head Bolt, 8mm Lock Washer, & 8mm Flat Washer

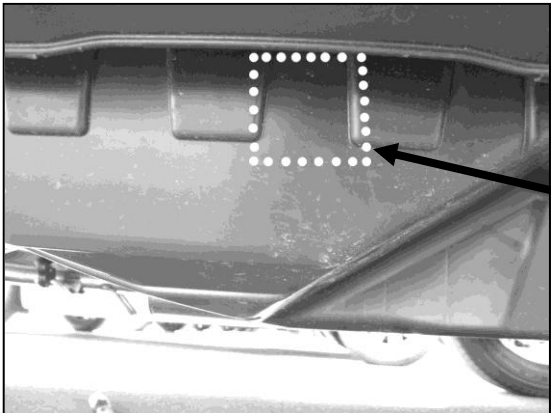
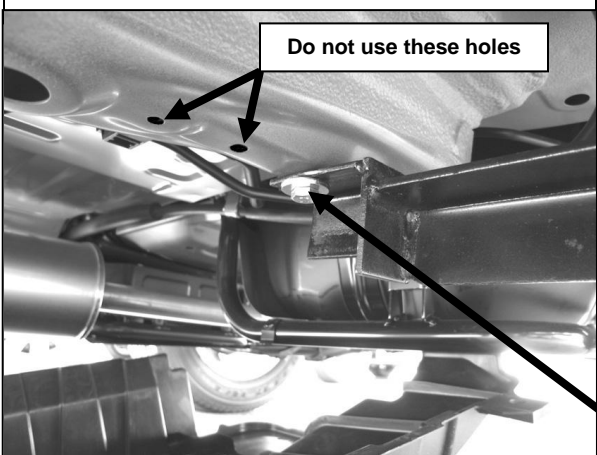

Figure 2

Rear Driver Side Mounting Bracket Shown



Installation Complete

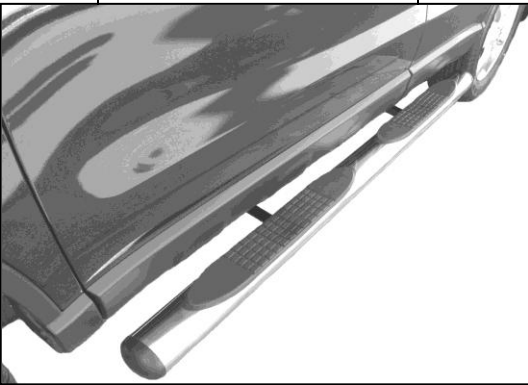

Figure 4

Figure 3

8mm x 30mm Hex Head Bolt,
8mm Lock Washer, &
8mm Flat Washer

