

Truck Champ

INSTALLATION INSTRUCTIONS OVAL SIDE BAR

**1997-03 FORD F-150/250 LD SUPER CAB, EXT. CAB
PART# 190162 190163**

<u>QTY.</u>	<u>CONTENTS</u>
2	oval side tubes
2	Front brackets
2	rear brackets
4	bolt plates-large
12	bolt plate –small (97 & 98 ext. Cab only)
12	3/8" flat washer
12	3/8" lock washer
12	3/8" hex nut
8	5/16" bolts
8	5/16" flat washers
8	5/16" lock washers

Step 1 Remove contents from box and verify all part are present. Read instructions completely before beginning.

Step 2 Remove plugs and install front and rear brackets by placing bolt plate through hole in body panel. (see figure 1)

Step 3 Install front and rear brackets as shown. Hand tighten (see figure 2).

Step 4 Line bracket holes with the those of the oval tube. Assemble 1/4" hardware.

Step 5 Make sure step bar and brackets are properly aligned. Tighten and torque 5/16" hardware to 19 ft-lbs. and 1/4" hardware to 9 ft-lbs.

FIGURE 1

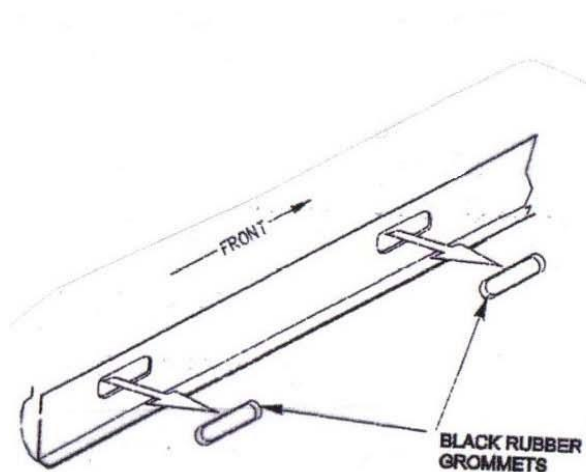
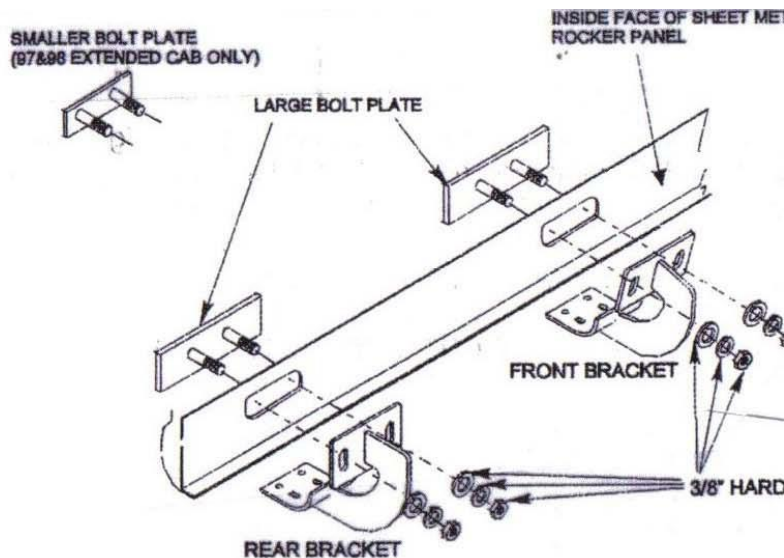

FIGURE 2



Finish protection- our products have a high finish that must be maintained such as any other high finish product on the vehicle. Protect the finish with a non-abrasive automotive wax. The use of soap, polish, or wax that contains abrasives is detrimental, as the compounds scratch the finish and open it to corrosion.

Disclaimer- buyer assumes all risk and liability whatsoever from the installation and use of our products. Our products are sold as decorative accessories and should not be relied upon as protection for the vehicle or occupants in the event of a collision or roll over.